



Wind Driven Optimization Approach based Multi-objective Optimal Power Flow and Emission Index Optimization

Nabil Mezhoud^{1,*}, Bilel Ayachi¹, Ahmed Bahri²



¹ Electrical Engineering Department, University of 20th August 1955-Skikda, Algeria.

² Department of Science and Technology, Ghardaia University, Algeria.

*Corresponding authors email: n.mezhounab@univ-skikda.dz

DOI: <https://doi.org/10.54392/irjmt2223>

Received: 26-12-2021; Revised: 03-03-2022; Accepted: 07-03-2022; Published: 11-03-2022

Abstract: This paper proposes one of the optimization methods based on atmospheric motion. It is a global optimization nature-inspired method such as Wind Driven Optimization (WDO) approach to solve the Optimal Power Flow (OPF) and Emission Index (EI) in electric power systems. Our main aim is to minimize an objective function necessary for a best balance between the energy production and its consumption, which is presented as a nonlinear function, taking into account of the equality and inequality constraints. The WDO approach is nature-inspired, population based iterative heuristic optimization algorithm for multi-dimensional and multi-modal problems. WDO method have been examined and tested on the standard IEEE 30-bus system and IEEE 57-bus system with different objectives that reflect total active power generation cost, the active power losses and the emission index. The results of used method have been compared and validated with known references published recently. The results are promising and show the effectiveness and robustness of proposed approach.

Keywords: Optimization, Swarm intelligence, Optimal power flow, Emission index, Wind driven optimization.

Nomenclature

Symbols	Definition
a_k, b_k, c_k	Cost coefficients w/o valve-point.
d_k, e_k	Cost coefficients w/ valve-point.
$\alpha_k, \beta_k, \gamma_k, \zeta_k, \lambda_k$	Emission coefficients
$f(x, u)$	Objective function.
f_1	Cost function w/o valve-point.
f_2	Cost function with valve-point
f_3	Power losses function.
f_4	Emission index function
f_5	Cost and active loss function
f_6	Cost and emission function
f_7	Cost, power loss and emission
$g(x, u)$	Inequality constraints.
$h(x, u)$	Equality constraints.
n_b	Total number of buses.
n_{br}	Total number of branches.
n_g	Total number of generators.
n_L	Total number of branches.
n_T	Total number of transformers
n_{Com}	Total number of compensators
T	Tap settings transformers.
u	Control variables vector
x	Stat variables vector

1. Introduction

Electric power systems engineering has the longest history of development compared to the various fields of engineering. In electrical supply systems, there are a wide range of problems involved in system optimization [1]. Among these problems, power system scheduling is one of the most important in system operation, control, and management.

Electric power plants that operate on Esoteric-fuel are among the most prominent sources of air pollution and contribute to causing great harm to the environment due to the burning of raw fuels such as coal, gas, and oil [2]. The burning of coal contributes a large proportion of polluting gases to the Earth's atmosphere, as it produces large amounts of Carbon oxides CO₂, and some toxic and dangerous gases such as emissions of Sulfur oxides SO_x, and Nitrogen oxides, NO_x. The quantity and nature of the pollutant depends on the type and quality of the used fuel [2, 3].

After implementation of the 1990 amendment to the United States Clean Air Act and increasing public awareness of environmental protection and public utilities, electricity production companies were obligated to adapt their designs and making strategy to reduced pollution rate and emissions of electric power plants [3, 4].

The emission index, or environmental index, is considered an important indicator from a conservation point of view [4]. Several strategies have been proposed and discussed to reduce atmospheric emissions.

The OPF problem has a long history of development of more than 58 years [1]. Since the OPF problem was first discussed by Carpenter in 1962, then formulated by Dommel and Tinney in 1968 [5].

The main purpose of solving the OPF problem is to calculate the optimal operating condition of the power system and corresponding settings for the economic operation of the control variables, by optimizing a specific objective taking into account economic and security constraints, such as equality and inequality constraints [1, 6, 7].

Over the past few years, many methods have been used to solve the OPF and EI problems like; Quadratic programming method (QP) [8], Newton and Qassi-Newton methods [9-11], Linear and non-linear programming methods, and nonlinear internal point methods (IPM) [12-16].

In the last two decades, and in order to solve the OPF and EI problems, several methods of optimization are formulated such as Artificial bee colony (ABC) and Incremental artificial bee colony [17-25], Bacterial foraging algorithms (BFA) and hybrid fuzzy based Bacterial foraging algorithm [26-27], Artificial neural networks (ANN) [29, 30], Harmony search (HS) [31, 32], Cuckoo search algorithm (CSA) [33], Evolution programming (EP) [34, 35], Differential evaluation (DE) [36-39], Modified differential evaluation (MDE) [40-44], Tabu search (TS) [45-47], Simulated annealing (SA) [48-49], Gravitational search algorithms (GSA) [50-52], Evolutionary algorithm [53-55], Genetic algorithms (GA) [56-60], Particle swarm optimization (PSO) [61-69], Modified Particle swarm optimization (MPSO) [70-72], Distributed Sobol Particle swarm optimization (DSPSO) [73], Ant colony optimization (ACO) [74-79], Firefly Algorithm (FFA) [80-82], Tree-seed algorithm (TSA) [83], Sine-cosine algorithm (SCA) [84], Crow search algorithm (CSA) [85], Hybrid particle swarm optimization-differential evolution (FAHSPSO) [86], Modified imperialist competitive algorithm (MICA) [87], Grey wolf optimizer (GWO) [3, 38, 88-96], Shuffled frog leaping algorithm (SFLA) and Modified SFLA [48, 97]-[98], Electromagnetism-like mechanism method (ELM) [99], Ant-lion optimizer [100], Interior search algorithm [101], and more recently the Wind driven optimization (WDO) method [102-112] were successfully utilized since their introduction to the literature as single objective optimization algorithm, Machine Learning and Modified grasshopper optimization Algorithms [113,114], Rao Algorithm [115], Hamiltonian Technique [116], Artificial Eco System optimization [117-118], Teaching-Learning-Studying-Based Optimization [119] and Combining Deep Learning [120], Artificial Fish Swarm Algorithm [121]. Variants of these algorithms

were proposed to handle multi-objective functions in electric power systems.

The WDO is a natural-inspired algorithm based on heuristics techniques [105]. This promising algorithm is implemented firstly to solve the electromagnetic problems in communication engineering studies [106].

2. Problem Formulation

The OPF and EI are nonlinear optimization problems, represented by a predefined objective function f , subject to a set of equality and inequality constraints [18, 64]. Generally, these problems can be expressed as follows.

$$\text{Min } f(x, u) \quad (1)$$

Subject to

$$h(x, u) = 0 \quad (2)$$

$$g(x, u) \leq 0 \quad (3)$$

$$x_{\min} \leq x \leq x_{\max} \ \& \ u_{\min} \leq u \leq u_{\max} \quad (4)$$

Where $f(x, u)$ is a scalar objective function to be optimised, $h(x, u)$ and $g(x, u)$ are, respectively, the set of nonlinear equality constraints represented by the load flow equations and inequality constraints consists of state variable limits and functional operating constraints. x and u are the state and control variables vectors respectively. x_{\min} , x_{\max} , u_{\min} and u_{\max} are the acceptable limits of variables. Hence, state variables vectors x can be expressed as given

$$x^t = \{P_{G_1}, |V_{L_1}|, \dots, |V_{L_{n_L}}|, Q_{G_1}, \dots, Q_{G_{n_g}}, S_1, \dots, S_{n_{br}}\} \quad (5)$$

Where, P_G , Q_G , V_L and S_k are the generating active power at slack bus, reactive power generated by all generators, magnitude voltage of all load buses and apparent power flow in all branches, respectively. n_g , n_L and n_{br} are, respectively, the total number of generators, the total number of load buses and the total number of branches.

The set control parameters are represented in terms of the decision vector u as follows:

$$u^t = \{P_{G_2}, \dots, P_{G_{n_g}}, |V_{G_1}|, \dots, |V_{G_{n_g}}|, Q_{L_{com}}, \dots, Q_{L_{com}}, T_1, \dots, T_{n_r}\} \quad (6)$$

Where, P_G are the active power generation excluding the slack generator, V_G are the generators magnitude voltage, T is tap settings transformers, and Q_{com} are the reactive power compensation by shunt compensator, n_r and n_{com} are the total number of transformers and the total number of compensators units, respectively.

2.1. Single-Objective Function

In general, the single-objective function is a nonlinear programming problem. In this paper, four single objectives commonly found in OPF and EI have been considered who are the generation cost without and with valve-point effect, f_1 and f_2 , respectively, the active power losses f_3 , and the emission index optimization f_4 .

2.1.1. Cost Without Valve-Point Optimization

The objective function of cost optimization f_1 of quadratic cost equation for all generators as given below

$$f_1 = \min \sum_{k=1}^{n_g} C(P_{gk}) = \min \sum_{k=1}^{n_g} a_k + b_k P_{gk} + c_k P_{gk}^2 \quad (7)$$

Where f_1 is the total generation cost in (\$/h)? P_{gk} and n_g are the active power output generated by the i^{th} generator and the total number of generators. a_k, b_k and c_k are the cost coefficients of the generator k .

2.1.2. Cost with valve-point optimization

Generally, when every steam valves begins to open, the valve-point shows rippling. However, the characteristics of input-output of generation units make nonlinear and non-smooth of the fuel costs function. To consider the valve-point effect, the sinusoidal function is incorporated into the quadratic function [18, 19]. Typically, this function is represented as follows

$$f_2 = \min \sum_{k=1}^{n_g} [a_k + b_k P_{gk} + c_k P_{gk}^2] + |d_k \sin(e_k (P_{gk}^{\min} - P_{gk}))| \quad (8)$$

Where d_k and e_k are the cost coefficients of unit with valve-point effect.

2.1.3. Active Power Loss Optimization

The active power loss function f_3 in (MW) to be minimized can be expressed as follows

$$f_3 = \sum_{k=1}^{n_b} G_{kj} [V_k^2 + V_j^2 - 2V_k V_j \cos \theta_{kj}] \quad (9)$$

Where, V_k and V_j are the voltage magnitude at buses k and j , respectively, G_{kj} is the conductance of line kj , θ_{kj} is the voltage angle between buses k and j and n_b is total number of buses.

2.1.4. Emission optimization

The emission function is the sum of exponential and quadratic functions of real power generating. Using

a quadratic equation, emission of harmful gases is calculated in (ton/h) as given below

$$f_4 = \min \sum_{k=1}^{n_g} 10^{-2} (\alpha_k + \beta_k P_{gk} + \gamma_k P_{gk}^2) + \zeta_k \exp(\lambda_k P_{gk}) \quad (10)$$

Where, f_4 is the emission function in (ton/h), $\alpha_k, \beta_k, \gamma_k, \zeta_k$ and λ_k are the emission coefficients of the generator k .

2.2. Bi-objective Function

2.2.1. Cost and active power loss optimization

When the optimization is the cost and the active power losses together, the bi-objective function as given below

$$f_5 = f_{Bi-objective} = \omega_1 f_1 + \omega_2 f_3 \quad \text{or} \quad \omega_1 f_2 + \omega_2 f_3 \quad (11)$$

Where ω_1 and ω_2 are the weighting factors.

2.2.2. Cost and Emission Optimization

Emission is needs to minimize the generation cost and emission. The objective function is

$$f_6 = \min(f_1 + Df_4) = \min(f_2 + Df_4) \quad (12)$$

f_6 is the total cost-emission in (\$/h), and D is the price penalty factor in (\$/ton).

2.2. Multi-Objective Optimization

All objective functions discussed before are used to solve the multi-objective OPF and EI problems. Therefore, the multi-objective problems can be stated as follows

$$f_7 = \omega_1 f_1 + \omega_2 f_3 + \omega_3 f_4 \quad \text{or} \quad \omega_1 f_2 + \omega_2 f_3 + \omega_3 f_4 \quad (13)$$

The function used in the case of weighted aggregation is given by equation (12).

$$MinF = \sum_{i=1}^{n_f} \omega_i f_i \quad \text{with} \quad \omega_i \geq 0 \quad \text{and} \quad \sum_{i=1}^{n_f} \omega_i = 1 \quad (14)$$

Where, $\sum_{i=1}^{n_f} \omega_i = 1$ & $i = 1 : n_f$, ω_i is the weighting factor and n_f is the number of objective function.

2.3. Equality Constraints

These equality constraints are the sets of nonlinear load flow equations that govern the power system, i.e.:

$$\begin{cases} P_{gk} = P_k + P_{Lk} \\ Q_{gk} - Q_{comk} = Q_k + Q_{Lk} \end{cases} \quad (15)$$

Where P_{gk} and Q_{gk} are, respectively, the scheduled active and reactive power generations at bus k . P_k, Q_k are the active and reactive power injections at bus k . P_{Lk}, Q_{Lk} and Q_{comk} are the active and reactive power loads at bus k and the reactive power compensation at bus k .

2.4 Inequality Constraints

The inequality constraints $g^{(x,u)}$ are represented by the system operational and security limits, listed below

- ✓ *Active and reactive power generations limits:*

$$P_{gk}^{\min} \leq P_{gk} \leq P_{gk}^{\max} \quad \text{where } k = 1, \dots, n_g \quad (16)$$

$$Q_{gk}^{\min} \leq Q_{gk} \leq Q_{gk}^{\max} \quad \text{where } k = 1, \dots, n_g \quad (17)$$

- ✓ *Voltage magnitudes and angles limits:*

$$V_k^{\min} \leq V_k \leq V_k^{\max} \quad \text{where } k = 1, \dots, n_b \quad (18)$$

$$\theta_k^{\min} \leq \theta_k \leq \theta_k^{\max} \quad \text{where } k = 1, \dots, n_b \quad (19)$$

- ✓ *Tap settings transformers limits:*

$$T_k^{\min} \leq T_k \leq T_k^{\max} \quad \text{where } k = 1, \dots, n_T \quad (20)$$

- ✓ *Reactive power compensation limits:*

$$Q_{comk}^{\min} \leq Q_{comk} \leq Q_{comk}^{\max} \quad \text{where } k = 1, \dots, n_{com} \quad (21)$$

Where, n_b, n_T, n_{com}, T and Q_{com} are total number of buses, the total number of transformers, the total number of compensators, the transformers tap settings and the reactive power compensation, respectively.

- ✓ *Security constraint limits:*

$$S_{kj} \leq S_{kj}^{\max} \quad \text{where } k = j = 1, \dots, n_{br} \quad (22)$$

S_{kj}^{\max} is the maximum apparent power flow.

2. Wind Driven Optimization Technique

The WDO algorithm was first introduced in 2010 [108]. The WDO is one of the optimization methods based on atmospheric motion, and it is global optimization nature-inspired method. This technique works on population based global heuristic algorithms for multi-dimensional and multi-dimensional models in the research field to apply constraints [104, 107].

3.1. Context Theory and Destination Of WDO

In the atmosphere, wind blows in an effort to make equal air pressure [106]. More exclusively, the air is used to move from high pressure to low pressure at a velocity, which is proportional to the pressure gradient [104]. Furthermore, some assumptions and simplifications are formulated in derivation of the WDO algorithm. The starting point in the development of WDO is with Newton's second law of motion, which is known to provide very accurate results when applied to the analysis of atmospheric motion [106].

$$\rho \vec{\omega} = \sum \vec{F}_i \quad (23)$$

Where, $\vec{\omega}$ is the acceleration vector, ρ is the air density for an infinitesimal air parcel, and \vec{F}_i are the all forces acting on the air parcel [108]. The equation that relates air pressure to its density and temperature is given by the ideal gas law, formulated as follows

$$P = \rho RT \quad (24)$$

In Eq. (24), P, R and T are, respectively, the pressure, the universal gas constant, and the temperature. In Eq. (23), there are four main forces that either cause the wind to move in a specific direction or deflect it from its path [102]. The most observable force causing the air to move is the pressure gradient force \vec{F}_{PG} , although the friction force \vec{F}_F , the gravitational force \vec{F}_G and the Coriolis force \vec{F}_C [104, 108]. Knowing that the force of the degree of pressure acting a very important role in air movement.

By assuming air has a finite volume (δV), the physical force equation because of pressure gradient can be expressed as [102].

$$\vec{F}_{PG} = -\vec{\nabla} P \delta V \quad (25)$$

The frictional force oppose the air parcel motion started by F_{PG} , and can be expressed as

$$\vec{F}_F = -\rho \alpha \vec{v} \quad (26)$$

The gravitational force pull the air parcel to the center of the earth expressed as

$$\vec{F}_G = \rho \delta V \vec{g} \quad (27)$$

The Coriolis is caused by the rotation of earth, and deflects the path of wind from one dimension to another. This force will work in such a way that velocity in one direction is influenced by velocity of another direction [108]. It can be expressed as

$$\vec{F}_C = -2\Omega \vec{v} \quad (28)$$

Where, $\vec{\nabla}P$ is the pressure gradient, δV represents an infinitesimal air volume, α is the frictional coefficient, \vec{v} is the wind velocity vector, \vec{g} is the gravitational acceleration, and Ω represent the rotation of earth.

Taking for simplicity, the acceleration equal to $(\Delta u/\Delta t)$, the time step $\Delta t = 1$ and $\delta V = 1$. Therefore, the summation of including \vec{F}_{PG} , \vec{F}_F , \vec{F}_G , and \vec{F}_C in the total force described in Eq. (25) can be rewritten as

$$\begin{aligned} \rho \Delta \vec{v} &= \rho \vec{v} \Delta t = \vec{F}_{PG} + \vec{F}_F + \vec{F}_G + \vec{F}_C \\ &= \rho \vec{g} + (-\vec{\nabla}P) + (-\rho \alpha \vec{v}) + (-2\Omega \vec{v}) \end{aligned} \tag{29}$$

The change in velocity in Eq. (29) can be extracted from modifying the Eq. (30) based on Eq. (24) and division by $(RT/P_{(k)})$ [109].

$$\begin{aligned} \Delta \vec{v} &= \vec{v}_{(k+1)} - \vec{v}_{(k)} \\ &= \vec{g} + (-\vec{\nabla}P \frac{RT}{P_{(k)}}) - \alpha \vec{v}_{(k)} + (-\frac{2\Omega \vec{v}_{(k)} RT}{P_{(k)}}) \end{aligned} \tag{30}$$

The vector g can be written as $g = |g|(0 - x(k))$ [103, 109]. The pressure gradient is the force that attempts to move an air parcel from its current position into optimal pressure. It can be expressed as $-\vec{\nabla}P = |P_{(opt)} - P_{(k)}|(x_{(opt)} - x_{(k)})$. All coefficients in the last term of Eq. (30) are collected to be a single term as $c = -2|\Omega|RT$ [111]. Eq. (30) can be modified as in Eq. (31).

$$\begin{aligned} \vec{v}_{(k+1)} &= \left[(1 - \alpha) \vec{v}_{(k)} \right] + \left[-\vec{g}(x_{(k)}) \right] + \\ &\frac{RT}{P_{(k)}} \left[P_{(opt)} - P_{(k)} \right] (x_{(opt)} - x_{(k)}) + \frac{c \vec{v}_{(k)}}{P_{(k)}} \end{aligned} \tag{31}$$

On the basis of ideal gas law equation from Eq. (24), and for simplicity, assuming that a single time step ($\Delta t = 1$), the air density, ρ can be written as the pressure [104]. Based on Newton's second law of motion, the velocity vector, v is

$$\begin{aligned} \vec{v}_{(k+1)} &= (1 - \alpha) \vec{v}_{(k)} - \vec{g}(x_{(k)}) + \\ &\left(\frac{P_{(opt)}}{P_{(k)}} - 1 \right) RT (x_{(opt)} - x_{(k)}) - \frac{c \vec{v}_{(k)}}{P_{(k)}} \end{aligned} \tag{32}$$

The updated velocity of the next iteration $v_{(k+1)}$ shown in Eq. (32) depends on the velocity of current iteration ($v_{(k)}$), the air parcel of current position in search space ($x_{(k)}$), the distance from the highest pressure point that has been found ($x_{(opt)}$), the maximum pressure ($P_{(opt)}$), the pressure at the current location ($P_{(k)}$), the temperature (T), the gravitational acceleration (g), the

universal gas constant R , the frictional coefficient α , and the Coriolis constant, c [102-107]. Air parcel position is updated, after the velocity of parcel given by Eq. (32) is updated. This can be expressed as

$$\vec{x}_{(k+1)} = \vec{x}_{(k)} + \vec{v}_{(k+1)} \Delta t \tag{33}$$

In Eq. (33), $\vec{x}_{(k)}$ represent that the air parcel vector would continue to move in its previous path with some opposition that is created due to friction. $\vec{v}_{(k+1)}$ is an attractive force that pulls against the center of coordinate system. The time step Δt supposing that is

the global best position. $\vec{x}_{(k+1)}$ is a vector represent the deflecting force [107 - 109]. The *WDO* permits the air parcels to move only in the interval $[-1, 1]$ for each dimension [110]. To check that the velocity amplitude is within the maximum and minimum limits in any dimension, the following equation is used [108].

$$v^* = \begin{cases} v_{\max} & \text{if } v_{(k+1)} > v_{\max} \\ -v_{\max} & \text{if } v_{(k+1)} < -v_{\max} \end{cases} \tag{34}$$

3.2. Implementation of WDO In OPF Problem

In order to implement the *WDO* method to solve the OPF and EI problems, the decision variables must be specified. The first step to execute the *WDO* method is the initialization, i.e. (the algorithm starts by randomly initializing the position and the velocity vectors). In the second step, after the execution of the optimization practice based on the *WDO* algorithm, the populations of air parcels are distributed randomly over the search space and at random velocities. In the third step, the values of the position and the velocity of each air parcel chosen in the previous step must be evaluated (objective function). The velocity would be updated and check the limits using Eq's. (32) and (34), respectively. In the fifth step, the position of each air parcel must be updated and outgoing air parcels are verified to avoid violating limits. The updating iterations are tested according Eq. (33). Then, the above procedure would be repeated until reaching the maximum iterations.

4. Simulation & Results

The proposed *WDO*-based algorithm for solving OPF and EI problems has been applied to the IEEE 30-bus and IEEE 57-bus test systems. The numerical and graphical results are represented in these sections.

4.1. IEEE 30-bus test system

The five generators system, IEEE 30-bus system is used throughout this work to test the proposed

algorithm. This system consists, 30 buses, 6 generators units and 41 branches, 37 of them are the transmissions lines and 4 are the tap changing transformers. One of these buses is chosen like as a reference bus (slack bus), the buses containing generators are taken the *PV* buses, the remaining buses are the *PQ* buses or loads buses. It is assumed that 9 capacitors compensation is available at buses 10, 12, 15, 17, 20, 21, 23, 24 and 29. The network data, the cost and emission coefficients of the five generators are referred in [122]. The one-line diagram of IEEE 30-bus system is shown in Figure 1.

The total loads of active and reactive powers are 283.4 (MW) and 126.2 (MVar), respectively, with 24 control variables. The basis apparent power used in this paper is 100 (MVA). The simulation results of load flow problem of test system are summarized in Table 1.

4.1.1. Case 1: Cost optimization

The objective functions of cost f_1 given in Eq. (7) is optimized. Therefore, in this case, the cost has

resulted in 801.1347 (\$/h), which is considered 8.3608 % lower than the initial case (load flow). Figure 2 shows the convergence characteristic of cost using *WDO* algorithm. Table 1 summarizes the optimal control variables of this case.

4.1.2. Case 2: Cost with valve-point effect optimization

The cost function f_2 given in Eq. (8) is optimized. Therefore, in this case, the cost has resulted in 826.37 (\$/h), which is considered 5.4742 % lower than the initial case. The convergence characteristic of cost optimization for this case is introduced in Figure 2. Table 1 summarizes the optimal control variables of this case.

4.1.3. Case 3: Active Power Loss Optimization

The optimal control variables of this case are introduced in Table 1.

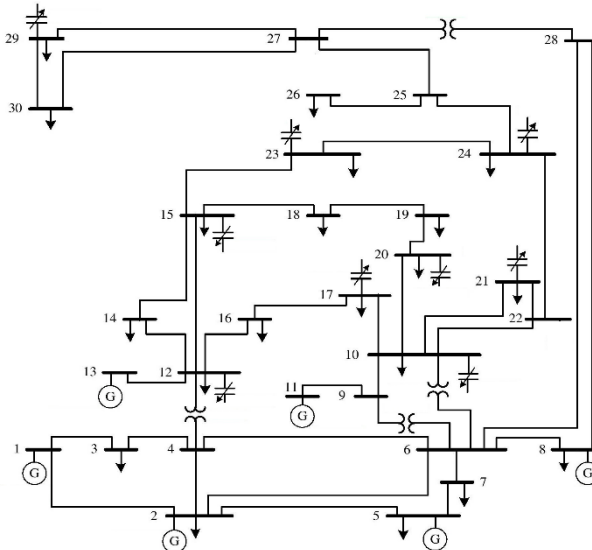

Figure 1. One-line diagram of IEEE 30-bus system.

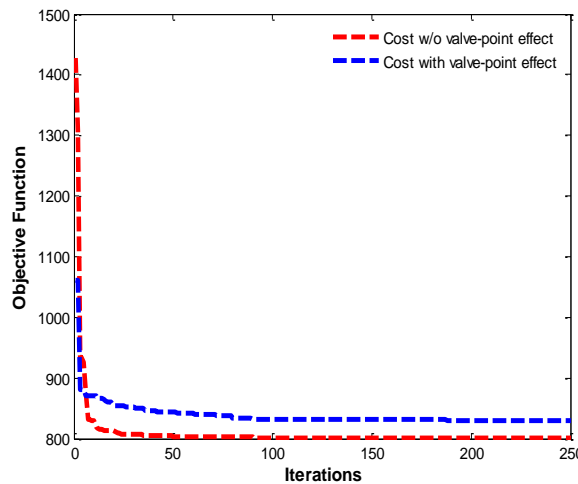

Figure 2. Convergence of algorithm for cases 1 and 2.

Table 1. Single objective results of IEEE 30-bus system.

Control variables	Optimal values					
	Basic Load flow	After optimization				
		Cost w/o valve	Cost w/ valve	Loss w/ valve	Loss w/o valve	Emission
		Case 1	Case 2	Case 3		Case 4
P_{G2} (MW)	40.0000	48.2030	29.4689	79.5519	79.6882	77.5750
P_{G5} (MW)	0.0000	21.8059	16.0676	49.7269	49.7604	50.0000
P_{G8} (MW)	0.0000	19.3977	10.0938	34.8591	35.0000	27.3119
P_{G11} (MW)	0.0000	13.4665	10.1456	29.7040	29.6496	30.0000
P_{G13} (MW)	0.0000	12.0000	12.0379	39.6966	40.0000	40.0000
V_1 (pu)	1.0600	1.0893	1.0671	1.0612	1.0565	1.0272
V_2 (pu)	1.0450	1.0672	1.0472	1.0546	1.0549	1.0289
V_5 (pu)	1.0500	1.0295	1.0006	1.0331	1.0392	0.9584
V_8 (pu)	1.0700	1.0359	1.0180	1.0426	1.0407	0.9567
V_{11} (pu)	1.0900	1.0568	1.1000	1.0509	1.0940	1.0239
V_{13} (pu)	1.0900	1.0333	1.0707	1.0501	1.0334	1.0671
Q_{com10} (MVar)	0.0000	4.0308	3.3442	4.3007	0.1324	1.4882
Q_{com12} (MVar)	0.0000	2.4727	4.2582	3.5066	2.5973	1.3674
Q_{com15} (MVar)	0.0000	2.8602	4.1133	3.1962	2.1219	5.0000
Q_{com17} (MVar)	0.0000	2.5035	4.4476	2.3281	0.3839	0.0559
Q_{com20} (MVar)	0.0000	3.4482	0.0652	4.6020	1.4640	1.8672
Q_{com21} (MVar)	0.0000	0.8353	2.0983	3.5938	2.7041	1.3149
Q_{com23} (MVar)	0.0000	3.1147	3.7974	4.9475	1.0174	0.0000
Q_{com24} (MVar)	0.0000	1.3913	3.3311	2.2424	3.5296	4.7243
Q_{com29} (MVar)	0.0000	2.2401	3.9877	4.3683	3.1557	3.4815
T_{6-9}	0.9780	1.0019	1.0081	1.0061	1.0370	0.9018
T_{6-10}	0.9690	1.0208	0.9984	1.0156	0.9963	1.0979
T_{4-12}	0.9666	0.9800	0.9919	1.0125	1.0084	1.0039
T_{28-27}	0.9320	0.9840	0.9597	1.0044	0.9817	0.9137
Cost in (\$/h)	874.2272	801.1347	826.3700	964.0800	1025.9600	954.3807
Active power loss in (MW)	17.5600	9.1924	12.1410	3.2327	3.2771	5.1640
Emission (ton/h)	4.1000	0.3117	0.3211	0.2161	0.2162	0.2150
Slack generator in (MW)	260.9600	177.7193	217.7273	53.0943	52.5789	63.6770
Average CPU time (s)	19.8200	105.3330	90.3453	88.4539	82.1792	108.4624

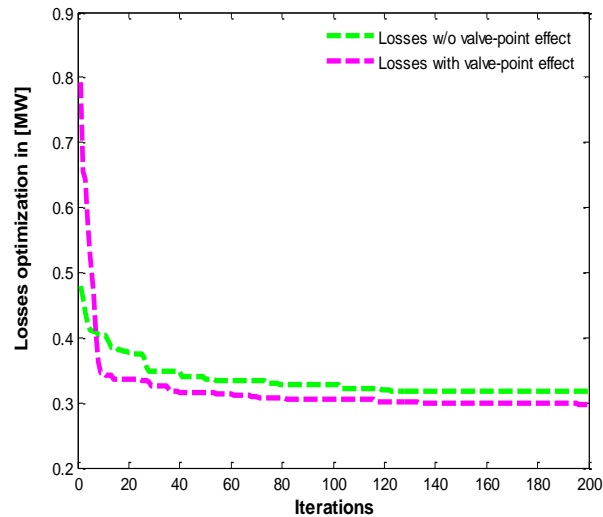

Figure 3. Convergence of algorithm for case 3.

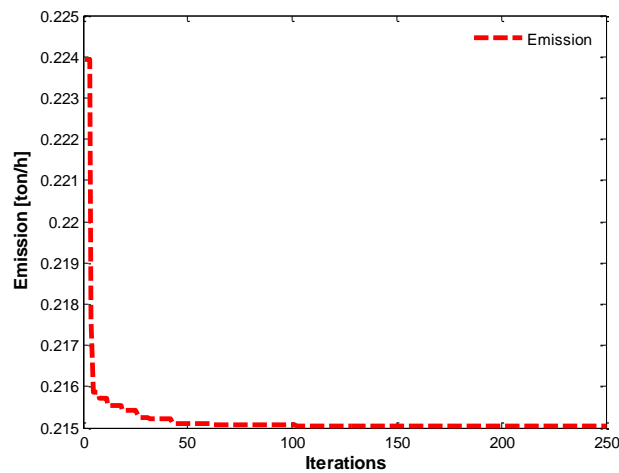

Figure 4. Convergence of algorithm for case 4.

Figure 3 shows the trend for convergence characteristics of active power losses using WDO algorithm. The active power loss minimization has dramatically decreased to 3.2327 (MW) and 3.2771 (MW) without and with valve-point effect, respectively, which is considered 81.5905 % and 81.3376 % lower than the basic case, that is, the case without optimization.

4.1.4. Case 4: Emission optimization

In this case, the emission reduction yielded 0.1763 (ton/h), which is considered 97.7962 % lower than initial case. The optimal settings of control variables for individual objective functions are detailed in Table 1. The convergence characteristics of emission using WDO method is shown in Figure 4.

4.1.5. Case 5: Cost and active loss optimization

The control variables of this case are tabulated in detail in Table 2. The cost in this case has resulted in 828.44 (\$/h) and 861.32 (\$/h) w/o and with valve-point,

respectively. The active power loss w/o and with valve-point effect are, respectively, 5.7412 (MW) and 6.3312 (MW).

4.1.6. Case 6: Cost and emission optimization

The bi-objective optimization considering the cost and the emission are tabulated in Table 2. The control variables of this case are tabulated in detail in Table 2. The cost has resulted in 801.41 (\$/h) and 826.29 (\$/h) w/o and with valve-point effect, respectively. Figure 5 shows the convergence characteristics obtained in cases 5 and 6.

4.1.7. Case 7: Cost, Active Power Loss and Emission

The IEEE 30-bus control variables of multi-objective considering cost, active power loss and emission are presented in detail in Table 2.

Table 2. Bi-objective results of IEEE 30-bus system

Control variables	Optimal values					
	Case 5		Case 6	Case 7		
	w/o valve	with valve	w/o valve	with valve	w/o valve-point	valve-point
P_{G2} (MW)	54.8769	48.6969	49.8438	28.2085	51.2691	52.6613
P_{G5} (MW)	30.2127	27.5559	21.8352	15.9615	29.3629	28.9637
P_{G8} (MW)	34.0291	34.7321	21.3200	10.0390	34.8815	28.3500
P_{G11} (MW)	26.0009	22.2444	13.1581	10.0000	22.1273	22.6876
P_{G13} (MW)	21.4080	21.3438	12.0000	12.0000	22.3051	22.3247
V_1 (pu)	1.0708	1.0766	1.0781	1.0890	1.0737	1.0794
V_2 (pu)	1.0588	1.0612	1.0627	1.0576	1.0589	1.0648
V_5 (pu)	1.0286	1.0339	1.0302	1.0266	1.0298	1.0363
V_8 (pu)	1.0421	1.0463	1.0394	1.0318	1.0412	1.0400
V_{11} (pu)	1.0695	1.0425	1.0217	1.0110	1.0526	1.0176
V_{13} (pu)	1.0465	1.0557	1.0261	0.9998	1.0419	1.0351
Q_{com10} (MVar)	1.9299	2.2378	2.3725	4.4450	4.6826	3.2852
Q_{com12} (MVar)	3.5779	2.7680	2.8893	4.3708	3.3781	1.3729
Q_{com15} (MVar)	4.2918	2.1745	1.8944	1.9876	3.9585	3.8477
Q_{com17} (MVar)	2.1102	2.3225	3.1717	4.6924	1.1924	2.4007
Q_{com20} (MVar)	2.2800	3.6888	2.3260	4.3612	3.0944	1.9439
Q_{com21} (MVar)	2.0265	2.3431	1.9763	4.3877	2.3942	3.6115
Q_{com23} (MVar)	2.6643	1.5274	1.6074	2.1420	4.6949	2.3554
Q_{com24} (MVar)	2.2253	2.0667	3.6352	4.3589	2.3718	2.0941
Q_{com29} (MVar)	3.9133	2.3475	1.5725	0.1540	1.1799	3.3638
T_{6-9}	0.9809	0.9753	1.0293	1.0801	0.9914	0.9890
T_{6-10}	1.0281	0.9985	0.9314	1.0017	1.0167	0.9832
T_{4-12}	1.0128	0.9823	1.0146	0.9950	1.0157	0.9978
T_{27-28}	0.9987	0.9824	1.0357	0.9273	0.9878	0.9453
Cost in (\$/h)	828.4400	861.3200	801.4100	826.2900	822.5800	863.0300
Active power loss in (MW)			8.9817	11.9343	6.0390	6.4499
Emission in (ton/h)	0.2524	0.2557	0.3106	0.4700	0.2499	0.1783
Slack generator in (MW)	122.6137	135.1582	174.2246	219.4134	129.4931	134.8625
Average CPU time (s)	112.5017	121.6664	99.8236	95.8352	79.0636	73.8949

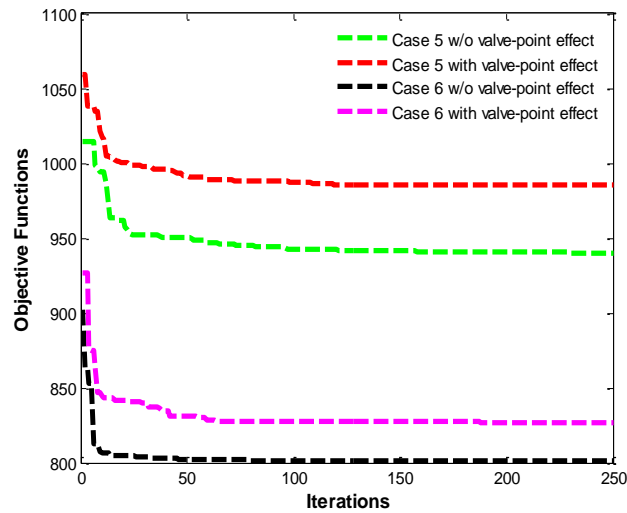

Figure 5. Convergence of algorithm for cases 5 and 6.

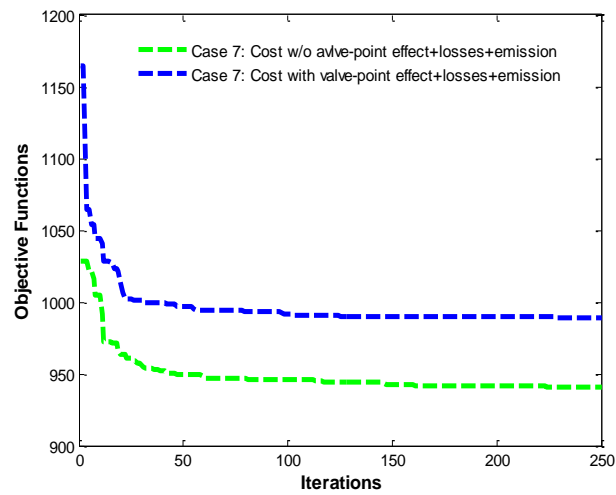

Figure 6. Convergence of algorithm for case 7.

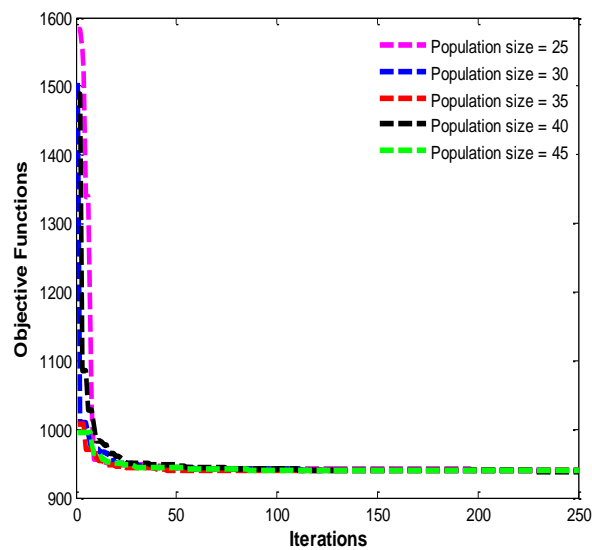

Figure 7. Convergence algorithm for case 7 with different population size.

When the valve-point is not in consideration, the generation cost is the 822.58 (\$/h) and 863.03 (\$/h) with valve-point effect is in consideration. The active power losses and emission w/o and with valve-point effect for this case are, respectively, 6.039 (MW), 6.4499 (MW), 0.2499 (ton/h) and 0.1783 (ton/h).

Figure 6 shows the convergence characteristics of multi-objective optimization obtained in case 7 without and with valve-point effect with respect to the number of generation under cost optimization, losses optimization and emission optimizations using proposed method.

For the IEEE-30 bus system, 24 control variables (5 generators outputs excluding slack bus, 6 generators magnitude voltages, 4 transformers tap and 9 reactive powers compensators) were optimized. Under the same conditions i.e. control variables limits, constraints and system data, the optimal solutions of IEEE 30-bus test system using the *WDO* algorithm reported in this paper are compared to some other techniques reported in the literature.

The parameters of *WDO* method used in this paper are the friction coefficient, $\alpha=0.4$, the gravitational constant $g=0.2$, the wind velocity vector, $v=3$, the coefficient $RT=3$ and the Coriolis constant, $c=0.4$.

The developed *WDO* has been implemented and used to solve the OPF and EI problems of IEEE 30-bus system under varying operating conditions. Figure 7 shows the convergence characteristics of *WDO* method for case 6 with various population sizes applied to IEEE 30-bus system.

It is clearly shown that the *WDO* could effectively find the optimum solution before the maximum iteration was reached.

The proposed method to solve the OPF and the EI problems is considered to have given the best results because the results obtained using the *WDO* method are

better compared to those published recently in several researches papers.

From Figures 5 and 6, all cases study of bi-objective and multi-objective results obtained the minimum values after 120 iterations.

4.2. IEEE 57-bus test system

In this case, the IEEE 57-bus system is considered to investigate the effectiveness of the proposed algorithm. The IEEE 57-bus system consists of 7 generators at buses 1, 2, 3, 6, 8, 9, and 12, 17 transformers are located at branches 19, 20, 31, 37, 41, 46, 54, 58, 59, 65, 66, 71, 73, 76, and 80, 3 shunts are considered at buses 18, 25 and 53, and 80 transmission lines. The single-line diagram of this system and the detailed data are given in [89].

4.2.1. Case 1: Cost optimization

The optimal settings of control variables for individual objective functions are detailed in Table 3. The convergence characteristic of this case is shown in Figure 8.

4.2.2. Case 2: Cost and power losses optimization

The optimal settings of control variables for bi-objective functions are detailed in Table 3. The convergence characteristic of this case is shown in Figure 8.

4.2.3. Case 3: Cost and emission optimization

The optimal settings of control variables for bi-objective functions are detailed in Table 3. The convergence characteristic of this case is shown in Figure 8.

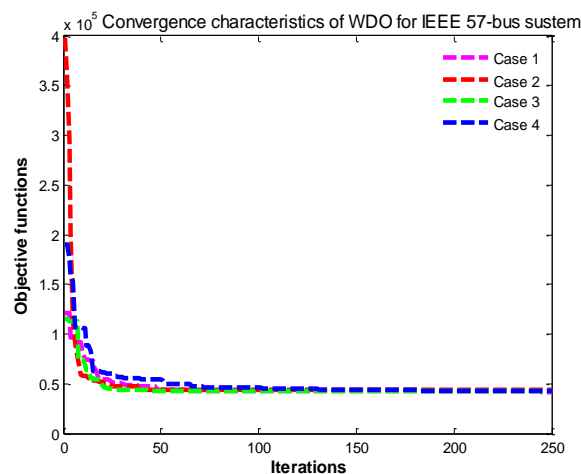

Figure 8. Convergence algorithm for cases 1, 2, 3 and 4 of IEEE 57-bus system.

Table 3. Results of cases 1,2,3 and 4 of IEEE 57-bus system

Control variables	Optimal values			
	Case 1	Case 2	Case 3	Case 4
P_{G2} (MW)	54.6750	71.4940	91.6446	43.0780
P_{G3} (MW)	73.2220	74.9188	43.1966	81.3522
P_{G6} (MW)	59.9617	15.2784	55.7033	42.9193
P_{G8} (MW)	482.8535	501.7457	503.7254	474.0350
P_{G9} (MW)	98.0371	35.0817	31.7962	58.8914
P_{G12} (MW)	336.7256	383.2472	388.1839	389.1949
V_1 (pu)	1.0339	1.0094	1.0549	1.0024
V_2 (pu)	1.0238	0.9962	1.0489	0.9914
V_3 (pu)	1.0283	1.0129	1.0356	1.0145
V_6 (pu)	1.0389	1.0318	1.0408	1.0295
V_8 (pu)	1.0365	1.0506	1.0439	1.0432
V_9 (pu)	1.0185	1.0290	1.0124	1.0271
V_{12} (pu)	1.0361	1.0519	1.0104	1.0546
Q_{com18} (MVar)	6.2847	10.9428	28.5455	14.7010
Q_{com25} (MVar)	19.4961	15.0816	20.3682	14.9048
Q_{com53} (MVar)	18.8091	15.3732	20.1136	9.9356
T_{4-18}	1.0181	0.9721	0.9765	0.9860
T_{4-18}	0.9366	0.9880	1.0544	1.0089
T_{21-20}	1.0331	1.0687	1.0546	0.9787
T_{24-25}	1.0428	0.9617	1.0062	1.0060
T_{24-25}	0.9499	0.9863	1.0062	1.0094
T_{24-26}	0.9779	0.9732	0.9981	1.0603
T_{7-29}	1.0351	0.9692	0.9963	0.9922
T_{32-34}	1.0354	1.0058	1.0342	1.0079
T_{11-41}	0.9365	0.9975	0.9864	1.0170
T_{15-45}	0.9537	0.9190	0.9796	0.9402
T_{14-46}	0.9994	1.0349	0.9960	1.0269
T_{10-51}	1.0011	0.9867	0.9953	0.9702
T_{13-49}	0.9735	1.0581	0.9925	1.0203
T_{11-43}	1.0853	0.9658	0.9584	0.9746
T_{40-56}	0.9419	1.0243	1.0366	0.9895
T_{39-57}	0.9664	0.9654	0.9619	1.0027
T_{9-55}	1.0132	1.0426	0.9637	1.0173
Cost in (\$/h)	42075.10	42436.76	41883.07	42388.09
Power losses in (MW)	23.89496	23.0491	27.1184	20.6044
Emission in (ton/h)	2.2788	3.2567	1.9167	2.4624
Slack generation (MW)	164.1014	189.2383	154.0954	179.5996
CPU time (min)	23.6500	20.2135	21.2408	18.0218

Table 4. Comparison of obtained results for the case 4 of IEEE 30-bus system.

Methods	Ref.	Cost (\$/h)	Losses (MW)	Emission (\$/ton)
Proposed	-	954.3807	5.1640	0.2150
GA	[3]	936.6200	9.7000	0.2117
HGA	[28]	984.9400	10.4300	-
MSA	[53]	944.5003	3.2858	0.2048
MPSO	[53]	879.9464	7.0467	0.2324
PSGWO	[96]	944.5120	3.2358	0.2048
DE	[23]	963.0010	-	-
MDE	[53]	927.8066	4.8539	0.2092
MFO	[53]	945.4553	3.4295	0.2048
FPA	[53]	948.9490	4.4920	0.2052
ABC	[17]	944.4391	3.2470	0.2048
IABC	[24]	-	-	0.1943
MOGWO	[3]	945.3785	3.5519	0.2049
CSA	[85]	950.9308	3.5708	0.2010
HPSO-DE	[86]	-	-	0.2048
Methods	Ref.	Cost (\$/h)	Losses (MW)	Emission (\$/ton)
Proposed	-	801.4100	5.7412	0.2524
MSA	[53]	859.1915	4.5404	0.2289
EGA	[42]	822.8700	5.6130	-
TLBO	[42]	828.5300	5.2883	-
IABC	[24]	854.9136	4.9820	0.2280
PSO	[25]	878.8731	7.8109	0.2253
MPSO	[53]	859.5841	4.5409	0.2287
DE	[42]	828.5900	5.6900	-
PSOGSA	[60]	822.4063	5.4681	-
MDE	[53]	868.7138	4.3891	0.2252
MFO	[53]	858.5812	4.5772	0.2294
FPA	[53]	855.2706	4.7981	0.2295
MOGW	[88]	847.9695	4.5886	0.2229
MICA	[87]	848.0544	4.5603	1.4171

Table 5 Comparison of obtained results for the cases 6 and 7 of IEEE 30-bus system.

Methods		Cost (\$/h)	Losses (MW)	Emission (\$/ton)
Methods	Ref.			
Case 6				
Proposed	-	863.0300	8.9817	0.3106
GA	[3]	892.9601	7.705	0.2270
ABC	[23]	820.1666	6.7244	0.2712
PSO	[23]	822.0920	-	0.2680
MICA	[87]	865.0660	4.5703	0.2221
MOGWO	[3]	866.9852	5.3740	0.2229
	[88]	833.8528	-	0.2451
Case 7				
Proposed	-	863.0300	6.4499	0.1783
GA	[60]	793.6054	8.4501	0.1878
IABC	[24]	851.6111	4.8731	0.2230
ABC	[24]	854.9166	4.9820	0.2280
FAHSPSO-DE	[86]	867.9808	5.5638	0.2666

4.2.4. Case 4: Cost, losses and emission optimization

The optimal settings of control variables for multi-objective functions are detailed in Table 3. The convergence characteristic of this case is shown in Figure 8.

Tables 4 and 5 shows a comparison between the obtained single and multi-objective results of costs, power losses and emission with the results obtained in literature.

5. Conclusion

The WDO approach is successfully implemented in this paper to find the optimum control variables of OPF and EI problems for several cases studies using two power systems which are IEEE 30-bus and IEEE 57-bus test systems.

The versatility of the OPF and the EI are illustrated by different cases by changing of the parameters of the WDO approach such as the friction coefficient, α , the gravitational constant g , the velocity vector of the wind, v , the RT coefficient and the Coriolis constant, c .

The WDO approach is considered to have the capacity to get global solutions with stable convergence, and this is clear from the results obtained from all cases of simulations mentioned previously. Therefore, it can be recommended to future researchers as a promising this

algorithm for solving some more complex engineering optimization problems. However, we have to mention that it becomes slow if the numbers of system variables are increased. It is found that the CPU time increases rapidly as system size increases (number of variables augmented) and the convergence slows down.

Finally, the result obtained by WDO approach is quite comparable with other methodology used for the OPF and EI problems.

References

- [1] C. Kumar, Ch. P. Raju, Constrained OPF using Particle Swarm Optimization, International Journal of Emerging Technology and Advanced Engineering, 2 (2012) 235-241.
- [2] J.H. Talaq, Ferial, M.E. El-Hawary, A Summary of Environmental/economic Dispatch Algorithms, IEEE Transactions on Power Systems, 9 (1994) 1508-1516. [\[DOI\]](#)
- [3] A. A. A. Mohamed, A. A. M. El-Gaafary, Y. S. Mohamed, A. M. Hemeida, (2016) Multi-Objective Modified Grey Wolf Optimizer for OPF, IEEE Eighteenth International Middle East Power Systems Conference (MEPCON), IEEE, Egypt. [\[DOI\]](#)
- [4] S. A. H. Soliman, A. A. H. Mantawi, (2012) Modern Optimization Techniques with

- Applications in Electric Power Systems, Springer Nature, Switzerland. [\[DOI\]](#)
- [5] H.W. Dommel, W.F. Tinney, Optimal Power Flow Solutions, IEEE Transactions on Power Apparatus and Systems, 87 (1968) 1866-1876. [\[DOI\]](#)
- [6] L.L. Lai, J.T. Ma, R.Yokoyama, M.Zhao, Improved Genetic Algorithms for Optimal Power Flow under both Normal Contingent Operation States, International Journal of Electrical Power & Energy Systems, 19 (1997) 287-292. [\[DOI\]](#)
- [7] B. Mahdad, K.Srairi, A Study on Multi-objective Optimal Power Flow under Contingency using Differential Evolution, Journal of Electrical Engineering and Technology, 8 (2013) 53-63. [\[DOI\]](#)
- [8] H. Nicholson, M. J. H. Sterling, Optimum Dispatch of Active and Reactive Generation by Quadratic Programming, IEEE Transactions on Power Apparatus and Systems, 72 (1973) 644-654. [\[DOI\]](#)
- [9] A. Santos, G. R.M. Da Costa, Optimal power flow Solution by Newton's Method Applied to an Augmented Lagrangian Function, IEE Proceedings-Generation, Transmission and Distribution, 42 (1995) 33-36. [\[DOI\]](#)
- [10] G.R.M.da Costa, C.E.U. Costa, Improved Newton Method for Optimal Power Flow Problem, International Journal of Electrical Power & Energy Systems, 22 (2000) 459-462. [\[DOI\]](#)
- [11] T.C. Giras, S.N. Talukdar, Quasi-Newton Method for Optimal Power Flows, International Journal of Electrical Power and Energy Systems, 3 (1981) 59-64. [\[DOI\]](#)
- [12] B. Stott, E. Hobson, Power System Security Control Calculations Using Linear Programming, Part-1, IEEE Transactions on Power Apparatus and Systems, 97 (1973) 1713-1720. [\[DOI\]](#)
- [13] B. Stott, E. Hobson, Power System Security Control Calculations using Linear Programming, Part-2, IEEE Transactions on Power Apparatus and Systems, 97 (1978) 1721-1731. [\[DOI\]](#)
- [14] A.M. Sasson, Nonlinear Programming Solutions for Load-Flow, Minimum-Loss, and Economic Dispatching Problems, IEEE Transactions on Power Apparatus and Systems, 88 (1969) 399-409. [\[DOI\]](#)
- [15] F. Capitanescu, M. Glavic, D. Ernst, L. Wehenkel, Interior-point Based Algorithms for the Solution of Optimal Power Flow Problems, Electric Power Systems Research, 77 (2007) 508-517. [\[DOI\]](#)
- [16] J. Gunda, G. Harrison, S.Z. Djokic, Analysis of Infeasible cases in Optimal Power Flow Problem, International Federation of Automatic Control, 49 (2016) 23-28. [\[DOI\]](#)
- [17] M.R. Adaryani, A. Karami, Artificial Bee Colony Algorithm for Solving Multi-objective Optimal Power Flow Problem, International Journal of Electrical Power & Energy Systems, 53 (2013) 219-223. [\[DOI\]](#)
- [18] S. Özyön, C. Yasar, G. Ozcan, H. Temurtas, An Artificial Bee Colony Algorithm Approach to Nonconvex Economic Power Dispatch Problems with Valve Point Effect, In National Conference on Electrical, Electronics and Computer, (2011) 294-299.
- [19] D. Aydın, S. Özyön, Solution to Non-convex Economic Dispatch Problem with Valve Point Effects by Incremental Artificial bee Colony with Local Search, Applied Soft Computing, 13 (2013) 2456-2466. [\[DOI\]](#)
- [20] D. L. Le, N. D. Vo, P. Vasant, Artificial Bee Colony Algorithm for Solving Optimal Power Flow Problem, The Scientific World Journal, (2013) 1-10. [\[DOI\]](#)
- [21] S. Mouassa, T. Bouktir, Artificial Bee Colony Algorithm for Solving OPF Problem Considering the Valve Point Effect, International Journal of Computer Applications., 112 (2015) 45-53.
- [22] P. Lu, J. Zhou, H. Zhang, R. Zhang, C. Wang, Chaotic Differential Bee Colony Optimization Algorithm for Dynamic Economic Dispatch Problem with Valve-point Effects, International Journal of Electrical Power and Energy Systems, 62 (2014) 130-143. [\[DOI\]](#)
- [23] L. Slimani, T. Bouktir, Economic Power Dispatch of Power Systems with Pollution Control using Artificial Bee Colony Optimization, Turkish Journal of Electrical Engineering & Computer Sciences, 21(2013) 1515-1527. [\[DOI\]](#)
- [24] X. He, W. Wang, J. Jiang, L. Xu, An Improved Artificial Bee Colony Algorithm and Its Application to Multi-Objective Optimal Power Flow, Energies, 8 (2015) 2412-2437. [\[DOI\]](#)
- [25] J.C. Bansal, S.S. Jadon, R. Tiwari, D. Kiran, B.K. Panigrahi, Optimal Power Flow using Artificial Bee Colony Algorithm with Global and Local Neighborhoods, International Journal of System Assurance Engineering and Management, 8 (2014) 2158–2169. [\[DOI\]](#)

- [26] Z. Zakaria, T.K.A. Rahman, E. E. Hassan, (2014) Economic Load Dispatch via an Improved Bacterial Foraging Optimization, In: IEEE 8th International Power Engineering and Optimization Conference, Malaysia. [\[DOI\]](#)
- [27] P.K. Hota, A.K. Barisal, R. Chakrabarti, Economic Emission Load Dispatch through Fuzzy Based Bacterial Foraging Algorithm. International Journal of Electrical Power and Energy Systems 32 (2010) 794-803. [\[DOI\]](#)
- [28] W. Bai, I. Eke & K. Y. Lee, An Improved Artificial Bee Colony Optimization Algorithm based on Orthogonal Learning for Optimal Power Flow Problem, Control Engineering Practice, 61 (2017) 163-172. [\[DOI\]](#)
- [29] L.L. Lai, (1998). Intelligent System Applications in Power Engineering: Evolutionary Programming and Neural Networks, John Wiley & Sons, USA.
- [30] T.S. Dillon, Artificial Neural Network Applications to Power Systems and Their Relationship to Symbolic Methods, International Journal of Electrical Power & Energy Systems, 13 (1991) 66-72. [\[DOI\]](#)
- [31] A.H. Khazali, M. Kalantar, Optimal Reactive Power Dispatch Based on Harmony Search Algorithm, International Journal of Electrical Power and Energy Systems, 33 (2011) 684-692. [\[DOI\]](#)
- [32] K. Pandiarajan, C.K. Babulal, Fuzzy Harmony Search Algorithm based Optimal Power Flow for Power System Security Enhancement, International Journal of Electrical Power & Energy Systems, 78 (2016) 72-79. [\[DOI\]](#)
- [33] S.M. Abd-Elazim, E.S. Ali, Optimal Power System Stabilizers design via Cuckoo Search algorithm, International Journal of Electrical Power & Energy Systems, 75 (2016) 99-107. [\[DOI\]](#)
- [34] J. Yuryevich, K. P. Wong, Evolutionary Programming based Optimal Power Flow Algorithm, IEEE Transactions on Power Systems. 14 (1999) 1245 -1250. [\[DOI\]](#)
- [35] Y.R. Sood, Evolutionary Programming based Optimal Power Flow and its Validation for Deregulated Power system Analysis, Electrical Power and Energy Systems, 29 (2007) 65-75. [\[DOI\]](#)
- [36] A.A. Abou El Ela, M.A. Abido, S.R. Spea, Optimal Power Flow using Differential Evolution Algorithm, Electric Power Systems Research, 91 (2010) 878-885. [\[DOI\]](#)
- [37] K. Vaisakh, L. R.Srinivas, Evolving ant Direction Differential Evolution for OPF with non-smooth cost Functions, Engineering Applications of Artificial Intelligence, 24 (2011) 426-436. [\[DOI\]](#)
- [38] A.A. Abou El Ela, M.A. Abido, S.R. Spea, Optimal Power Flow using Differential Evolution Algorithm, Electrical Engineering, 91 (2010) 69-78. [\[DOI\]](#)
- [39] A.A. El-Fergany, H.M. Hasanien, Single and Multi-objective OPF using Grey Wolf Optimizer and Differential Evolution Algorithms, Electric Power Components System, 43 (2015) 1548-1559. [\[DOI\]](#)
- [40] A.V. Babu, T. Ramana, S. Sivanagaraju, Analysis of Optimal Power Flow Problem based on Two Stage Initialization Algorithm, Journal of Electrical Power & Energy Systems, 55 (2014) 91-99. [\[DOI\]](#)
- [41] S. Sayah, K. Zehar, Modified Differential Evolution Algorithm for Optimal Power Flow with Non-smooth Cost Functions, Energy Conversion and Management, 4 (2008) 3036-3042. [\[DOI\]](#)
- [42] A.M. Shaheen, R.A. El-Sehiemy, S.M. Farrag, (2015) Optimal Power Flow using Forced Initialized Multi-Objective Differential Evolution Algorithm, 17th International Middle East Power Systems Conference, Mansoura University, Egypt.
- [43] D.L. Le, D.L. Ho, N.D. Vo A Hybrid Differential Evolution and Harmony Search for Optimal Power Flow, Global Journal of Technology & Optimization, 6 (2015) 1-6.
- [44] H.R. El-Hana Bouchekara, M.A. Abido, Optimal Power Flow using Differential Search Algorithm, Electric Power Components and Systems, 42 (2013) 1683-1699. [\[DOI\]](#)
- [45] M.A. Abido, Optimal Power Flow using Tabu Search Algorithm, Electric Power Components and Systems, 30 (2010) 469-483. [\[DOI\]](#)
- [46] Y.J. Jeon, J.C. Kim, Application of Simulated Annealing and Tabu Search for Loss Minimization in Distribution Systems, International Journal of Electrical Power and Energy Systems, 26 (2004) 9-18. [\[DOI\]](#)
- [47] K. Lenin, B.R. Reddy, M. Suryakalavathi, Hybrid Tabu Search-Simulated Annealing Method to Solve Optimal Reactive Power Problem, International Journal of Electrical Power and Energy Systems, 82 (2016) 87-91. [\[DOI\]](#)

- [48] T. Niknam, M.R. Narimani, R. Azizipanah-Abarghooee, A New Hybrid Algorithm for Optimal Power Flow Considering Prohibited Zones and Valve Point Effect, *Energy Conversion and Management*, 58 (2012) 197-206. [\[DOI\]](#)
- [49] C.A.R. Sepulveda, B.J.P. Lazo, A Solution to the Optimal Power Flow using Simulated Annealing, *International Journal of Electrical Power & Energy Systems*, 25 (2003) 47-57. [\[DOI\]](#)
- [50] A.R. Bhowmik, A.K. Chakraborty, Solution of Optimal Power Flow using non Dominated Sorting Multi-objective Gravitational Search Algorithm, *International Journal of Electrical Power and Energy Systems*, 62 (2014) 323-334. [\[DOI\]](#)
- [51] J. Radosavljević, D. Klimenta, M. Jevtić, N. Arsić, Optimal Power Flow using a Hybrid Optimization Algorithm of Particle Swarm Optimization and Gravitational Search Algorithm, *Electric Power Components and Systems*, 43 (2015) 1958-1970. [\[DOI\]](#)
- [52] S. Duman, U. Guvenç, Y. Sönmez, N. Yörükeren, Optimal Power Flow using Gravitational Search Algorithm, *Energy Conversion and Management*, 59 (2012) 86-95. [\[DOI\]](#)
- [53] A.A.A. Mohamed, Y.S. Mohamed, A.A.M. El-Gaafary, A.M. Hemeida, Optimal Power Flow using Moth Swarm Algorithm, *Electric Power Systems Research*, 142 (2017) 190-206. [\[DOI\]](#)
- [54] S.S. Reddy, P.R. Bijwe, Multi-Objective Optimal Power Flow using Efficient Evolutionary Algorithm, *International Journal of Emerging Electric Power Systems*, 18 (2015) 1-21. [\[DOI\]](#)
- [55] S.S. Reddy, P.R. Bijwe, A.R. Abhyankar, Faster Evolutionary Algorithm based Optimal Power Flow using Incremental Variables, *International Journal of Electrical Power & Energy Systems*, 54 (2014) 198-210. [\[DOI\]](#)
- [56] T.M. Mohan, T. Nireekshana, (2019) A Genetic Algorithm for Solving Optimal Power Flow Problem, In: *Proceedings of the Third International Conference on Electronics Communication and Aerospace Technology*, IEEE, India. [\[DOI\]](#)
- [57] C. Yasar, S. Ozypon, A New Hybrid Approach for Nonconvex Economic Dispatch Problem with Valve-Point Effect, *Energy*, 36 (2011) 5838-5845. [\[DOI\]](#)
- [58] T. Bouktir, L. Slimani, M. Belkacemi, A Genetic Algorithm for Solving the Optimal Power Flow Problem, *Leonardo Journal of Sciences*, 4 (2004) 44-58.
- [59] T.N. Malik, A. Asar, M.F. Wyne, S. Akhtar, A New Hybrid Approach for the Solution of Nonconvex Economic Dispatch Problem with Valve-Point Effects, *Electric Power Systems Research*, 80 (2010) 1128-1136. [\[DOI\]](#)
- [60] S.K. Mishra, S.K. Mishra, A Comparative Study of Solution of Economic Load Dispatch Problem in Power Systems in the Environmental Perspective, *Procedia Computer Science*, 48 (2015) 96-100. [\[DOI\]](#)
- [61] A.A.A. El-Ela, T. Fetouh, M.A. Bishr, R.A.F. Saleh, Power Systems Operation using Particle Swarm Optimization Technique, *Electrical Power Systems Research*, 78 (2008) 1906-1913. [\[DOI\]](#)
- [62] B. Sharma, S. Sehgal, A. Nain, Particle Swarm Optimization and Genetic Algorithm based Optimal Power Flow Solutions, *International Journal of Application or Innovation in Engineering & Management*, 2 (2013) 307-315.
- [63] R. Labdani, L. Slimani & T. Bouktir, Particle Swarm Optimization Applied to the Economic Dispatch Problem, *J. Electrical Systems*, 2(2) (2006) 95-102.
- [64] M.L. Reddy, M.R. Reddy, V.C.V. Reddy, Optimal Power Flow using Particle Swarm Optimization, *International Journal of Engineering Sciences & Emerging Technologies*, 4 (2012) 116-124.
- [65] M.A. Abido, OPF using Particle Swarm Optimization. *Electrical Power and Energy System*, *International Journal of Electrical Power & Energy Systems*, 24 (2002) 563-571. [\[DOI\]](#)
- [66] N. Mezhoud, S. Leulmi & A. Boukadoum, AC-DC OPF Incorporating Shunt FACTS Devices using HVDC Model and Particle Swarm Optimization Method, *International Review of Electrical Engineering (IREE)*, 9 (2014) 382-393.
- [67] R. Cabadag, B. E. Turkay, Heuristic Methods to Solve Optimal Power Flow Problem, *Journal of Electrical and Electronics Engineering*, 13 (2013) 1653-1659.
- [68] R.P. Singh, V. Mukherjee, S. P. Ghoshal, Optimal Power Flow by Particle Swarm Optimization with an Aging Leader and Challengers, *International Journal of Engineering, Science and Technology*, 7 (2015) 123-132. [\[DOI\]](#)

- [69] B.E. Turkay, R.I. Cabadag, (2013) Optimal Power Flow Solution using Particle Swarm Optimization Algorithm, EuroCons, IEEE, Croatia. [\[DOI\]](#)
- [70] J.Y. Kim, H.S. Lee, J.H. Park, A Modified Particle Swarm Optimization for Optimal Power Flow, Journal of Electrical Engineering and Technology, 2 (2007) 413-419. [\[DOI\]](#)
- [71] J. Hazra A. K. Sinha, A Multi-objective Optimal Power Flow using Particle Swarm Optimization, European Transactions on Electrical Power, 21 (2010) 1028-1045. [\[DOI\]](#)
- [72] R. Sripriya, R. Neela, WIPSO based Combined Emission Economic Dispatch, Advances in Natural and Applied Sciences, 10 (2016) 157-164.
- [73] P. Wannakarna, S. Khamsawang, S. Pothiya, S. Jiriwibhakorn, Optimal Power Flow Problem Solved by using Distributed Sobol Particle Swarm Optimization, ECTI International Conference on Electrical Engineering/Electronics, Computer, Telecommunications and Information Technology, IEEE, Thailand.
- [74] J.T. Soares, T. Sousa, Z.A Vale, H. Morais, P. Faria, Ant Colony Search Algorithm for the Optimal Power Flow Problem, In IEEE Power and Energy Society General Meeting, IEEE, USA. [\[DOI\]](#)
- [75] V. Raviprabakaran, R.C. Subramanian, Enhanced Ant Colony Optimization to Solve The Optimal Power Flow with Ecological Emission, International Journal of System Assurance Engineering and Management, 9 (2018) 58-69. [\[DOI\]](#)
- [76] R. Effatnejad, H. Aliyari, H. Tadayyoni, A. Abdollahshirazi, Novel Optimization Based on the Ant Colony for Economic Dispatch, International Journal on Technical and Physical Problems of Engineering (IJTPE), 15 (2013) 75-80.
- [77] A. Ketabi & A. A. R. Feuillet, Application of the Ant Colony Search Algorithm to Reactive Power Pricing in an Open Electricity Market, International Journal of Electrical Power & Energy Systems, 32 (2010) 622-628. [\[DOI\]](#)
- [78] B. Allaoua, A. Laoufi, Collective Intelligence for Optimal Power Flow Solution Using Ant Colony Optimization, Leonardo Electronic Journal of Practices and Technologies, 13 (2008) 88-105.
- [79] A. Qasim, L.T. Al-Bahrani, Constraint Optimal Power Flow Based on Ant Colony Optimization, Journal of Engineering and Sustainable Development, (2020) 274-283. [\[DOI\]](#)
- [80] S.S. Padaiyatchi, Hybrid DE/FFA Algorithm Applied for Different Optimal Reactive Power Dispatch Problems, Australian Journal of Electrical and Electronics Engineering, 17 (2020) 203-210. [\[DOI\]](#)
- [81] A. Khelifi, B. Bentouati, S. Chettih, Optimal Power Flow Problem Solution Based on Hybrid Firefly Krill Herd Method, International Journal of Engineering Research, 44 (2019) 213-228. [\[DOI\]](#)
- [82] A. Khan, H. Hizam, N. I. Ben Abdu-Wahab, Mohammad L. Othman, Optimal Power Flow using Hybrid Firefly And Particle Swarm Optimization Algorithm, Plos One, (2020) 1-21. [\[DOI\]](#)
- [83] A. El-Fergany, H.M. Hasanien, Tree-seed algorithm for solving optimal power flow problem in large-scale power systems incorporating validations and comparisons, Applied Soft Computing, 64 (2018) 307-316. [\[DOI\]](#)
- [84] A.F. Attia, R.A. El-Sehiemy & H. M. Hasanien, Optimal power flow solution in Power Systems using a Novel Sine-Cosine Algorithm, International Journal of Electrical Power & Energy Systems, 99 (2018) 331-343. [\[DOI\]](#)
- [85] A. Fathy, A. Abdelaziz, Single-objective Optimal Power Flow For Electric Power Systems Based on Crow Search Algorithm, Archives of Electrical Engineering, 67 (2018) 123-138.
- [86] E. Naderi, M. Pourakbari-Kasmaei, F. V. Cerna, M. Lehtonen, A Novel Hybrid Self-Adaptive Heuristic Algorithm to Handle Single- and Multi-objective Optimal Power Flow Problems, International Journal of Electrical Power & Energy Systems, 125 (2021) 1-17. [\[DOI\]](#)
- [87] M. Ghasemi, S. Ghavidel, M. M. Ghanbarian, M. Gharibzadeh, A.A. Vahed, Multi-objective Optimal Power Flow Considering The Cost, Emission, Voltage Deviation and Power Losses using Multi-Objective Modified Imperialist Competitive Algorithm, Energy, 78 (2014) 276-289. [\[DOI\]](#)
- [88] L. Dilip, R. Bhesdadiya, R.I. Trivedi, P. Jangir, Optimal Power Flow Problem Solution using Multi-objective Grey Wolf Optimizer Algorithm, Intelligent Communication and Computational Technologies In: Networks and Systems, (2018) 191-201. [\[DOI\]](#)
- [89] L.I. Wong, M.H. Sulaiman, M.R. Mohamed, M.S. Hong, Grey Wolf Optimizer for Solving Economic Dispatch Problems, IEEE

- International Conference on Power and Energy (PECon), IEEE, Malaysia. [\[DOI\]](#)
- [90] M. Pradhan, P.K. Roy, T. Pal, Grey wolf optimization applied to Economic Load Dispatch Problems, *Electrical Power and Energy System*, 83 (2016) 325-334. [\[DOI\]](#)
- [91] M. Pradhan, P.K. Roy, T. Pal, Oppositional based Grey Wolf Optimization Algorithm for Economic Dispatch Problem of Power System, *Ain Shams Engineering Journal*, 9 (2017) 2015-2025. [\[DOI\]](#)
- [92] M.H. Sulaiman, Z. Mustafa, M.R. Mohamed, O. Aliman, using the Gray Wolf Optimizer For Solving Optimal Reactive Power Dispatch Problem, *Applied Soft Computing*, 32 (2015) 286-292. [\[DOI\]](#)
- [93] Z.M. Gao, J. Zhao, An Improved Grey Wolf Optimization Algorithm with Variable Weights, *Hindawi Computational Intelligence and Neuroscience*, (2019) 1-13. [\[DOI\]](#)
- [94] S. Mirjalili, S.M. Mirjalili, A. Lewis, Grey Wolf Optimizer, *Advances in Engineering Software*, 69 (2014) 46-61. [\[DOI\]](#)
- [95] K.S. Kadali, R. Loganathan, M. Veerasamy, V. Jawalker, Environmentally Sustainable Economic Dispatch using Grey Wolves Optimization, *ARPJ Journal of Engineering and Applied Sciences*, 13 (2018) 2068-2079.
- [96] C.R.E.S. Rex, M.M. Beno, J. Annrose, Optimal Power Flow based Combined Economic and Emission Dispatch Problem using Hybrid PSGWO Algorithm, *Journal of Circuits, Systems, and Computers*, 28 (2018). [\[DOI\]](#)
- [97] A.K. Khamees, A.El-Rafei, N.M. Badra, A.Y. Abdelaziz, Shuffled Frog Leaping Algorithm, *International Journal of Engineering, Science and Technology*, 9 (2017) 55-68. [\[DOI\]](#)
- [98] T. Niknam, M.R. Narimani, M. Jabbari, A.R. Malekpour, A modified shuffle frog leaping algorithm for multi-objective optimal power flow, *Energy*, 36 (2011) 6420–6432. [\[DOI\]](#)
- [99] H.R. El-Hana Bouchekara, M.A. Abido, A.E. Chaib, Optimal Power Flow using an Improved Electromagnetism-like Mechanism Method, *Electric Power Components and Systems*, 44 (2016) 434-449. [\[DOI\]](#)
- [100] I.N. Trivedi, P. Jangir, S. A. Parmar, Optimal Power Flow with Enhancement of Voltage Stability and Reduction of Power Loss using Ant-Lion Optimizer, *Cogent Engineering*, 3 (2016). [\[DOI\]](#)
- [101] B. Bentouati, S. Chettih, L. Chaib, Interior Search Algorithm for Optimal Power Flow with Non-smooth Cost Functions, 4 (2017) 1-17. [\[DOI\]](#)
- [102] U. Ashwini, M.. E. A. Ravi, J. D. Sathyara, Wind Drive Optimization Based Economic Dispatch for the Effective Micro Grid Utilization, *International Journal of Advanced Research in Basic Engineering Sciences and Technology*, 3 (2017) 760-766.
- [103] M. Jevtić, N. Jovanović, J. Radosavljević, Solving a Combined Economic Emission Dispatch Problem using Adaptive Wind Driven Optimization, *Turkish Journal of Electrical Engineering and Computer Sciences*, 26 (2018) 1747-1758. [\[DOI\]](#).
- [104] P. Lakshminarayana, S. Ravindra, Wind Driven Optimization Technique: Optimal power flow problem, *Journal of Applied Engineering Research*, 12 (2017) 308-313.
- [105] H.H. Alhelou, M.E.H. Golshan, M.H. Fini, Wind Driven Optimization Algorithm Application to Load Frequency Control in Interconnected Power Systems Considering GRC and GDB Nonlinearities, *Electric Power Components and Systems*. 46 (2018) 1223-1238. [\[DOI\]](#)
- [106] Z. Bayraktar, M. Komurcu, D.H. Werner, (2010) Wind Driven Optimization (WDO): A Novel Nature-Inspired Optimization Algorithm and its Application to Electromagnetics, *IEEE Antennas and Propagation Society International Symposium, Canada*. [\[DOI\]](#)
- [107] Z. Bayraktar, M. Komurcu, Z.H. Jiang, D.H. P.L. Werner, (2011) Werneret, Stub-loaded Inverted-F Antenna Synthesis via Wind Driven Optimization, *Proceedings of IEEE International Symposium on Antennas and Propagation, USA*. [\[DOI\]](#)
- [108] B. Zongfan, Z. Yongquan, L. Liangliang, M. A. Mingzhi, Modeling, Optimization, and Verification for Complex Systems, *Hindawi Mathematical Problems in Engineering*, (2015) 1-20. [\[DOI\]](#)
- [109] O. Abdalla, H. Rezk, E. M. Ahmed, Wind Driven Optimization Algorithm based Global MPPT for PV System Under non-uniform Solar Irradiance, *International Solar Energy Society*, 180 (2019) 429-444. [\[DOI\]](#)
- [110] T.K. Ghosh, S. Das, Efficient Job Scheduling in Computational Grid Systems using Wind Driven Optimization Technique, *International Journal of Applied Metaheuristic Computing*, 9 (2018) 49-59. [\[DOI\]](#)
- [111] D. M. Mathew, C. Rani, M. R. Kumar, Y. Wang, R. Binns, K. Busawon, Wind Driven Optimization Technique for Estimation of Solar

- Photovoltaic Parameters, IEEE Journal of Photovoltaics, 8 (2019) 248 -256. [\[DOI\]](#)
- [112] R. Senthilkumar, P.S.k. Karimulla, K.B.V.S.R. Subrahmanyam, R. Deshmukh, Solution for Optimal Power Flow Problem Using WDO Algorithm, Turkish Journal of Computer and Mathematics Education, 12 (2021) 889-895. [\[DOI\]](#)
- [113] F. Hasan, A. Kargarian, A. Mohammadi, A Survey on Applications of Machine Learning for Optimal Power Flow, IEEE Texas Power and Energy Conference (TPEC), USA. [\[DOI\]](#)
- [114] M. A. Taher, S. Kamel, F. Jurado, M. Ebeed, Modified Grasshopper Optimization Framework for Optimal Power Flow Solution, Electrical Engineering, 101 (2019) 121-148. [\[DOI\]](#)
- [115] S. Gupta, N. Kumar, L. Srivastava, H. Malik, A. Anvari-Moghaddam, F.P.A. García Márquez, Robust Optimization Approach for Optimal Power Flow Solutions Using Rao Algorithms, Energies, 14 (2021) 1-28. [\[DOI\]](#)
- [116] H.T. Ul-Hassan, M.F. Tahir, K. Mehmood, K.M. Cheema, A.H. Milyani, Q. Rasool, Optimization of Power Flow by Using Hamiltonian Technique, Energy Reports, 6 (2020) 2267-2275. [\[DOI\]](#)
- [117] K. Bhattacharjee, K. Shah, J. Soni, Solving Economic Dispatch using Artificial Eco System-based Optimization, Electric Power Components and Systems, 50 (2022). [\[DOI\]](#)
- [118] H.H. Mohamed, S. Kamel, Q.S. Sinan, T. Khurshaid, M. Ebeed, Developing Chaotic Artificial Ecosystem-Based Optimization Algorithm for Combined Economic Emission Dispatch, IEEE Access, 9 (2021) 51146-51165. [\[DOI\]](#)
- [119] E. Akbari, M. Ghasemi, M. Gil, A. Rahimnejad & S. A. Gadsden, Optimal Power Flow via Teaching-Learning-Studying-Based Optimization Algorithm, Electric Power Components and Systems, 49 (2021) 584-601. [\[DOI\]](#)
- [120] P.I.V. Hentenyck, A. Velloso, Combining Deep Learning and Optimization for Preventive Security-Constrained DC Optimal Power Flow, IEEE Transactions on Power Systems, 36 (2021) 3618-3628. [\[DOI\]](#)
- [121] A.M. Kabir, M. Kamal, F. Ahmad, Z. Ullah, F.R. Albogamy, G. Hafeez, F. Mehmood, Optimized Economic Load Dispatch with Multiple Fuels and Valve-Point Effects Using Hybrid Genetic-Artificial Fish Swarm Algorithm, Sustainability, 13 (2021) 1-27. [\[DOI\]](#)
- [122] K.Y. Lee, M. El-Sharkawi, (2008) Modern Heuristic Optimization Techniques: Theory and Applications in Power Systems, John Wiley & Sons, USA. [\[DOI\]](#)

Author Biography



Dr. Nabil Mezhoud is a Lecturers Professor at the University of Skikda, Algeria. He received the Diploma of PhD in Electrical Engineering in 2017. He is published several research papers in Conferences, Journals and Reviews. Currently, He is Member of LES Laboratory and

Scientific Committee of the Electrical Engineering Department. His areas of interest are: Modeling, Simulation and Application of FACTS and HVDC Systems, Application of Intelligent Techniques to Optimal Power Flow (OPF) Problem, Hybrid and Multi-objective OPF, Power System Stability and Control, Integrating of Renewable Energy into Electrical Networks and Smart Grids Systems.

N. Mezhoud, Electrical Engineering Department, University of August 20th, 1955-Skikda, Algeria. Email: n.mezhounab@univ-skikda.dz, Phone: +(213) 6 58 55 13 40.



Dr. Bilel Ayachi He received the Engineer Degree in Electrical Engineering (Electrical Networks) from the University of August 20th, 1955, Skikda, Algeria, in 2004, MSc degree in Electrical Engineering (Modeling & Simulation of Electrical Power

Networks) from the same University in 2008 and PhD in 2020. He is a Lecturers Professor in Electrical Engineering Department in the University of August 20th, 1955, Skikda, Algeria. His areas of interest are: FACTS, HVDC Modeling and Simulation in Electrical Power Systems, Power Systems Stability and Optimal Power Flow (OPF) Problems.

B. Ayachi, Department of Electrical Engineering, University of August 20th, 1955, Skikda, Algeria, Email: b.ayachi@univ-skikda.dz, Phone: + (213) 6 70 47 12 19



Ahmed Bahri is Assistant Professor at the University of Ghardaia, Algeria. He received the MSc degree in Electrical Engineering from University of August 20th, 1955-Skikda, in 2009. He is published several research papers in conferences, journals and reviews. Currently,

He is Responsible for renewable energies, His areas of interest are: work on the optimization of the electrical energy produced by multi-source systems (renewable systems) subsequently injected into the electricity grid, Power System Stability and Control.

A. Bahri, Science and Technology Department, University of Ghardaïa, Algeria, bahridoc22@gmail.com, Phone: + (213) 6 76 98 63 29.

Conflict of interest

The Authors have no conflicts of interest to declare that they are relevant to the content of this article.

Does this article screened for similarity?

Yes

About the License

© The Author(s) 2022. The text of this article is open access and licensed under a Creative Commons Attribution 4.0 International License.