

Application of Smart Waste Management Strategies for Sustainable Waste Management

G. Senthilkumar^{1*}

¹ Department of Civil Engineering Annamalai University, Tamil Nadu, India.

*Corresponding author E-Mail ID: cdm.gsk@gmail.com

Doi: <https://doi.org/10.34256/irjmtcon91>

ABSTRACT

India is moving towards development of smart cities which requires a marked improvement in Municipal Solid Waste Management (MSWM) to provide a clean and aesthetically appealing environment specifically in urban agglomerations. Presently India is producing around 65 million tones of municipal solid waste annually and 80% of which is dumped simply on the open ground. Even after the Solid waste management rules 2016 comes into effect there is no marked improvement in the waste management. The use of technologies like Internet of Things (IoT) and adopting a policy of smart waste – smart resources it is possible to create more robust Sustainable solid waste management systems. IoT is a concept that connects numerous and various physical objects to the internet with the help of sensors and other wireless technologies, conceptually the process of connecting different types of devices extracting the data from them to perform an action in the context of data read. With Swatch Bharath, Clean India mission and the development of Smart cities projects the government of India is offering and encouraging a phenomenal change in waste management policies and action plans with an objective to make the waste management technically feasible, environmentally and financially sustainable. In the present study an assessment of existing waste management scenario was carried out for the semi urban location, Annamalai Nagar Special town Panchayat of Cuddalore District in Tamilnadu state. IoT based waste management has been proposed, the ill effects of the present waste management practices and likely benefits of the application of technology enhanced IoT based waste management have been compared for the real time waste management system.

Keywords: *Municipal solid waste management, Urban agglomerations, Smart waste, Smart resources, Sustainable waste management.*

1. INTRODUCTION

The management of municipal solid waste (MSW) consumes huge budgetary resources for its collection, transfer and transport, processing and disposal. MSW management in developing countries is inadequate, lacks direction, pose a challenge and opportunity for public and private sector. India is rapidly being urbanized and the growing population, changes in life style, the increased economic activity results in increased waste generation. Waste management around the world is expected to grow at an annual rate of 6.2% by 2023 with higher rate is expected in Asia Pacific region [1]. The MSW generation in India is around 65 million tons per year and presently we are adopting a strategy of cradle to grave. The unattended MSW has many negative consequences with possible impact on environment and health. As the country is the signatory for

many global conventions for protection of environment specifically to reduce green house emission, it is indeed very essential to reduce the total carbon emission from the waste management sector. Hence a technically proven waste management which takes into account the concept of circular economy, in which nothing will be left out of loop and all the matter entering the waste stream, should be returned back after its life cycle for remanufacturing, recycling and reuse repeatedly is the need of the hour. This can be achieved by adopting a policy of cradle to cradle. The policy initiatives in waste management can be complimented by technological breakthroughs and adaptation to recent advancement in terms of AI, ICT, IoT and Block chain management. As the internet has revolutionaries the world by global connectivity network, the IoT is also set to have a significant impact in the next generation of Internet [2]. IoT can include a large number of applications designed to assist many sectors like industry, market, transportation, education, healthcare, agriculture, waste management and more specifically in smart cities [3, 4], the figure 1 illustrates the various applications of IoT.

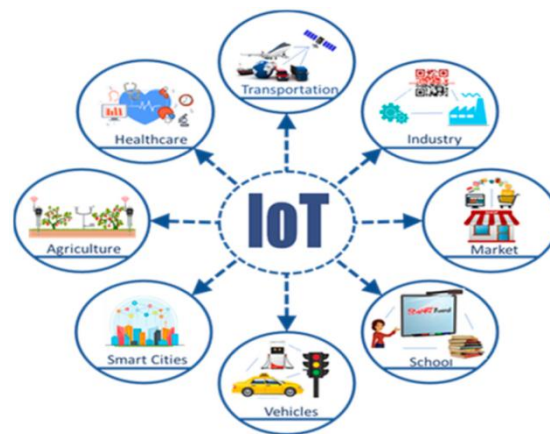

Fig 1. Illustration of Application and General framework of IoT

The smart city programs being implemented in India, aims for modern urbanization by utilizing both the existing and planned infrastructure investments to provide a better quality in terms of living, utilization of resources, improved transparency and integration of various systems. This integration of systems will work collectively to generate intelligent and actionable information for decision makers.

THE CONCEPT OF SMART CITIES

A smart sustainable city is an innovative city that uses information and communication technologies and other means to improve quality of life, efficiency of urban services, competitiveness, while ensuring that it meets the needs of present and future generations with respect to economic, social and environmental aspects. The basic idea of smart cities is rooted in the creation / connection of human and social capital in order to generate a greater and more sustainable economic development and improved living environment for all sections of the people. The smart city uses the network of infra for urban development, which ensures high quality of life with wise management of natural resources by participatory governance. The smart cities should be seen as system of system giving intelligent response and optimization at every level. Application of IoT / ICT enhances livability, workability and sustainability by collecting, communicating and crunching. A smart city collects information about itself through sensors, other devices and through existing systems and communicates that data using wired and wireless network. Finally it crunches the data to understand what's happening now and what's likely to happen next. The core infrastructure elements in smart city are adequate water supply, assured electricity, sanitation including solid waste management, efficient urban mobility and public transport, affordable housing for the poor, robust IT connectivity, digitalization, good governance

(e-governance), participatory urban planning and management. Under the smart city initiatives India propose to cover 100% of the households a regular door to door waste collection system, improving the waste collection efficiency at 100%, total segregation of waste at source and to ensure that recyclables are recycled at decentralized recycling plants.

STUDY AREA

Annamalai Nagar is a Special grade panchayat located at 11° 24' N latitude and 79°44'E longitude at a distance of 245 km south of Chennai, in Cuddler District of Tamilnadu. It also houses the Annamalai University, a unitary residential university which spreads over an area of 999 acres. The present population is around 12500, and 15000 students are pursuing their education in the university. Annamalai nagar generates around 2.94 ton of MSW per day at a rate of 150 gms / head / day. The reduced per capita waste generation is mainly due to mixed population that belongs to high, middle and low income group. Waste is being collected from 15 wards. It is found that around 35% of the population is covered under door to door collection of waste and the remaining is from street sweepings and from community dust bins. The composition analysis shows that 37.5% of the waste is biodegradable and the remains are recyclables. Presently 4 pushcart and only 3 tricycles are involved in primary collection with the help of 11 sanitary workers. The waste is simply being dumped on ground at location called thidalveli located at 0.5km and extends over 6.1 acres. Monitoring of entire solid waste management system is being done by the local body. Figure 2 show the location map of Annamalai nagar special panchayat.



Fig 2. Location map of Annamalai Nagar

CAPITAL INVESTMENT PLAN FOR SWM

The detailed project report prepared for improvement of existing infrastructure and to enhance the operational efficiency of SWM systems in Annamalai nagar by Tamilnadu urban infrastructure development project II identifies the capital investment requirement for the Annaamalai nagar special town panchayat which also covers the financial operating plan for the next fifteen years at Rs 975.01 lakhs. The proposed investment is expected to cover all the 3030 households and 119 commercial establishments with door to door collection and segregation of waste for composting and to the recycling facility.

PROBLEMS ASSOCIATED WITH THE EXISTING WASTE MANAGEMENT SYSTEM

Cities in the developing nations are finding it difficult to achieve the target of source segregation and to use different types of waste which can potentially be brought back to the consumer life cycle. It is estimated that 3 billion urban residents generated 1.4 billion tons of

waste during 2012 and this volume is expected to increase to 2.4 billion tons by 2025 for an urban population of 4.3 billion. One of the primary difficulties associated with the existing waste management is its inability to predict when trash is to be picked up based on the rate of filling or emptiness of the bins, so that trucks can be allowed to collect only upon the need arises, since more tuck means more time and more fuel and manpower.

Even after the notification and implementation of Solid Waste Management, rules 2016, there is no appreciable improvement in management of urban municipal solid waste. Most importantly it is observed that the waste is everywhere, it is in our mind and in our sight, scattered and the community dust bins are overflowing due to insufficient capacity and due to poor collection efficiency leading to unaesthetic / poor environmental setting. The present system largely depends on manual operations without any optimized waste management practices in terms of storage, collection, transfer, transport, processing and disposal. The cost for monitoring and management of municipal solid waste is also higher and the local body depends on external budgetary support for sustained waste management. The total cost incurred by the local body for the collection and disposal of one ton of waste is around Rs 3000 / ton of waste.

SMART WASTE MANAGEMENT SYSTEM

The smart waste management system are designed to address some of these issues and challenges and helps in source reduction, indicate the nature of waste using sensors, ensures continuous monitoring of waste streams, adopts optimized routing practices and helps in creating a closed loop economies using Internet of Things (IoT), thus less green house emission.

The smart city based on IoT, use the sensors, radiofrequency and actuators for monitoring and identification purpose, can be studied under three heads, (i) planning and execution of waste collection with dynamic adaptation to routes and restrictions, (ii) transport to appropriate places based on the nature of waste, (iii) recycling the recyclables [5]. The objective of Smart waste management is to reduce the improper utilization of valuable resources like human effort, time, fuel and overall cost. The smart system has been subdivided into four subsystem viz Smart Trash system, Smart Vehicle system, Local base station and smart monitoring and controlling Hut. All these systems are connected intelligently and connected to smart trash bins so as to know the status of the bin and to dispose of the waste bins as when it is required.

The bins will have RF transmitter, Ultrasonic sensor with Arduino UNO, which in turn sense the waste level in the bin and the RF signal is transferred when the bin is filled to specified load or level. The signal from the bins are received via RF receive in the central station. The signal from the smart trash bins are received in the local base station and the status of the trash bins can be monitored regularly from the monitoring and controlling hut. The smart monitoring and controlling hut consists of Arduino mega 2560, GSM/GPRS, GLCD screen and RF receive and communicate over the internet by the use of the PC at local base station. The total number of bins, details of city, ward, locality, and other particulars are displayed in the interface.

The smart vehicle system is web interlaced and keeps track with monitoring and controlling hut, for the jobs performed and waits for the new tasks. The smart vehicle will be connected with the smart bin and dumping site and use the use the robotic arm for disposing the trash bin. Once the bins are filled of trash the central system will send the SMS to the vehicle to go to the right place and to move to the next bin location. After the completion of the assigned task the vehicle move on to perform the next task assigned from the monitoring and control hut.

The interface at the smart monitoring and controlling hut has been developed using an object oriented programming language, can be viewed as an evolution of the classic visual basic and is implemented on the .NET frame work. The smart monitoring and controlling hut selects the vehicle keeping in view the distance, cost and other factors to achieve optimal cost for the work

done. The interface also provides an initial login page to authenticate the user, and directs the user to the control panel. The figure 3 show the block diagram of monitoring system used for smart waste management.

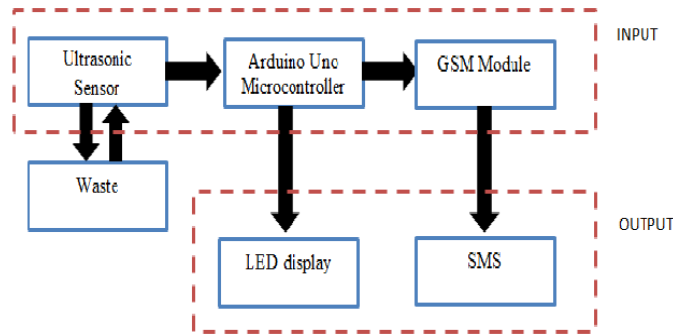

Fig 3: Monitoring

system block diagram

COMPONENTS / ARCHITECTURE OF WASTE MANAGEMENT

In the present study the concept of smart waste management has been tried for Annamalai nagar, using RF module, Arduino Uno and an Ultrasonic wireless sensor. In recent years RFID technology finds application domains such as logistics, inventory, public transportation and security. This technology is used for waste sorting based on information stored in the RFID tag.

The waste management architecture is built around several elements: waste items, bins, trash bags, collective containers, collection vehicles and control system. The flow of waste starts from individual items present in the waste and identified by waste description given in the digital information about the type of waste and ends up in collection vehicle for further processing and disposal.

The user is the principle element of the selective sorting process and based on this our waste management system proposes some pervasive assistance for selective sorting. To ensure proper treatment for the waste the items present in the trash bag and the numbers of items, its weight are to be taken into account. In this some digital information like owner of the trash bag, waste produced by each consumer, so that based on the analysis the it can be decide whether to accept the trash bag or not.

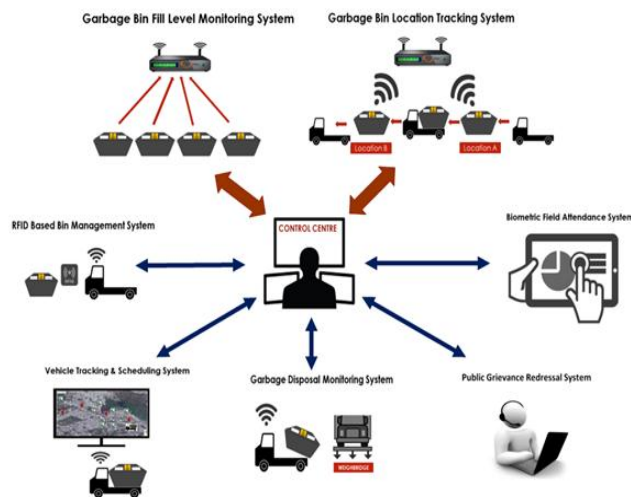

Fig 4. Components of Smart waste management system

The collective container determines the nature of waste, and decides whether the waste is to be accepted or not. The collective container will not open when the user brings in one type of waste instead of actually what he is supposed to bring in. During the collection of waste the toxic wastes which are not placed in the appropriate container can be detected. Figure 4 show the component of smart waste management system.

COST FOR SWM

The annual cost incurred by the Annamalai nagar special grade panchayat exclusively for SWM is around 32lakhs. An attempt has been made for arbitrarily establishing smart waste management system for Annamalai Nagar area by providing smart bin, local base station with smart monitoring and controlling hut and a smart vehicle for collection of waste.

The training and implementation of smart waste management system can be done with existing general budget as the total staff to be involved is around 20 only. Based on the market price the cost for smart waste bin of capacity 50kg to a serve a population of 12500 is estimated at 25.76lakhs. The protective gears for the sanitary workers cost around 1.93lakhs. The cost of preparing the land for disposal / processing of waste is Rs 50lakhs. Establishment of control hut with all ICT facilities 12lakhs. The cost for two number of smart vehicle smart vehicles is Rs 40lakhs. Hence with an initial investment of around 130 lakhs the conventional waste management system in Annamalai Nagar special panchayat can be converted into a smart waste management system. The smart wste management system proposed in the present study takes in to account from the point of waste generation to the point of waste disposal. The facilities which already exists can be utilized for composting the organic waste and the recyclables can be segregated and can be sold to the waste vendors. The finished compost and the sale of recyclables will offer continuous revenue to the local body.

CONCLUSIONS

To transform the conventional waste management into smart waste management basically required training and creation of infrastructure. Implementation of smart waste management systems for Annamalai Nagar Special panchayat with limited population is technically feasible and financially viable since it ensures optimized resource consumption and revenue generation. The creation of IoT infrastructure integrates the activities like identifying the bin locations, sorting, status of garbage filled in bins, location where immediate attention is required, optimized routing for collection vehicles and helps to achieve sustainable waste management. The success of smart waste management depends largely on the people's participation and the interface between the man and machine will enhance the participatory waste management.

REFERENCES

1. MICE Industry by Event type, Global Opportunity Analysis and Industry Forecast, 2017-2023. Available online, <https://www.alliedmarketresearch.com/MICE-industry-market> (31 March 2018).
2. Weber, M; Lucic; D; Lovrek.I, Internet of Things context of the smart city. IEEE Conf. Pub. 2017, 187-193 (cross ref).
3. Pellicer, S; Santa, G; Bleda, A.L; Maestre, R; Jara, A.J; Skarmeta, A.C, A Global perspective of Smart Cities: A Survey. Proceedings of the International conference on Innovative Mobile and Internet services in ubiquitous computing, Taichung, Taiwan, 3-5 July 2013, pp 439-444.
4. Raajen, T; Daneva, M, Depicting the smarter cities of the future: A systematic literature review & field study; Proceedings of the smart city symposium, Prague, Czech Republic, 25-26. May 2017, pp 1-10.

5. Anagnostopoulos, T; Zaslavsky, A; kolomvatsos, K; Medvedev,A; Amirian, P; Morley, J; Hasjiefthymiades, S, Challenges and Opportunities of Waste Management in IoT enabled smart cities: A survey, IEEE Trans, Sustain comput, 2017, 2, 25-289 (cross ref).

Conflict of Interest

The Author declare no conflict of interest

About the License

The text of this article is licensed under a Creative Commons Attribution 4.0 International License